



- ◆ 1 charging level
- ◆ Versions for lead-acid batteries, 2.5 to 12A ratings
- ◆ Charging current limitation selectable.

Automatic battery chargers for lead-acid batteries

With 1 charging level, BCE series

SEC. PAGE

18- 2



PAGE 18-2

- 1 CHARGING LEVEL**
- For lead-acid battery only, up to 150Ah rating
 - Rated output current:
 - 3A, 6A, 12A at 12VDC
 - 2.5, 5A, 10A at 24VDC
 - Input and output protection
 - Electronic lock for shorted battery, polarity inversion, low battery voltage and disconnected battery.

1 charging level

31 BCE 0312
31 BCE 2V52431 BCE 0612
31 BCE 052431 BCE 1212
31 BCE 1024

Order code	Rated output current	Rated output voltage DC	Qty per pkg	Wt
	[A]	[V]	n°	[kg]
1 charging level.				
31 BCE 0312	3	12	1	1.900
31 BCE 0612	6		1	4.750
31 BCE 1212	12		1	8.600
31 BCE 2V524	2.5	24	1	1.900
31 BCE 0524	5		1	4.925
31 BCE 1024	10		1	9.550

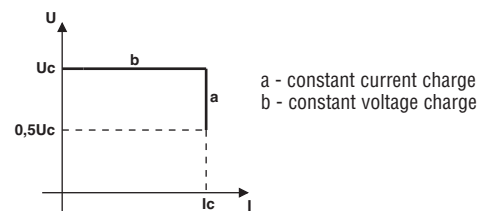

General characteristics

Controlled diode devices for use in civil and industrial systems.

Suitable for small and medium rated batteries (up to 150Ah) at 1 charging level.

Protections:

- Mains input fuse (except for BCE 2V5 and BCE 03)
- Battery output fuse
- Electronic lock in case of short circuit on battery terminals, battery polarity inversion, low voltage across battery poles (<0.5 Ue) and disconnected battery
- Alarm output:
 - Negative static, NPN transistor for BCE2V5 and BCE03
 - Relay for BCE05, BCE06, BCE10 and BCE12.

Indications:

- Power on
- Charge ($I > 0.2 I_c$)
- Alarm for protection tripping.

Operational characteristics

- Auxiliary supply voltage: 220-240VAC $\pm 10\%$, 50/60Hz $\pm 5\%$
- Charging current: 30-100% I_e adjustable
- Charging cycle: in accordance with DIN 41773 standards
- Current limitation
- Degree of protection: IP00
- Clamping screw terminal block with captive screws:
 - Removable for BCE03 and BCE2V5
 - Fixed for BCE05, BCE06, BCE10 and BCE12.

Type	Maximum power		Mains fuse	Output fuse
	consumption	dissipation		
	[VA]	[W]	[A]	[A]
BCE 0312	117	24	—	6.3
BCE 0612	222	46	4	12.5
BCE 1212	400	73	6.3	25
BCE 2V524	166	26	—	6.3
BCE 0524	317	40	4	12.5
BCE 1024	610	66	6.3	25

Certifications and compliance

Certifications obtained: GOST.

Compliant with standards: IEC/EN 60335-2-29, EN 50081-1, EN 50081-2, EN 50082-1, EN 50082-2.

DERATING CURVES

BCE 2V5 - BCE 03

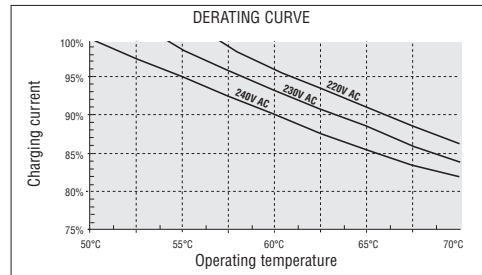

BCE 05 - BCE 06

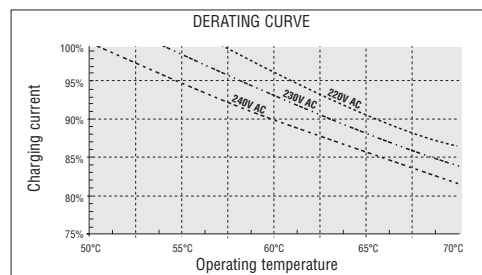

BCE 10 - BCE 12

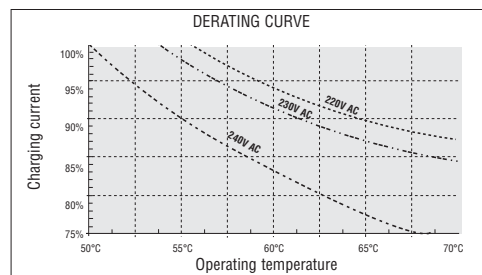

Installation

These battery chargers can be installed only in enclosed electrical panels having cover or door.

The mounting in vertical position is essential; the battery charger must be firmly fixed by 4 fixing screws.

At least 5cm of space on all four sides of the battery charger is required for adequate heat dispersion and free airflow.

A main switch, load-break or disconnect, must be installed upstream and must have at least 3mm contact clearance.

A mains protection fuse, 1A slow-blow type, is required for BCE2V5 and BCE03 types.

Connections

The supply of the battery charger is to be adequately protected by a fuse. The earth terminal must be connected although the battery charger is fixed to a metal plate.

It is good practice to place the battery charger as close as possible to the battery and to use connecting cables having a suitable cross section. Otherwise, the battery charger may not operate or charge correctly because of problems with voltage drops.

Alarms

BCE2V5 - BCE03

These types have a static alarm output for the control of a relay or indicator, maximum 300mA duty.

If it is connected to a relay, this must be normally energised in absence of alarm. In alarm conditions with ALARM LED switched on, or in absence of supply, the relay de-energises.

BCE05-BCE06-BCE10-BCE12

These types have a normally energised relay alarm output.

In alarm conditions with ALARM LED switched on, or in absence of supply, the relay de-energises.

Possible causes of alarm include:

- Low battery voltage
- Battery fuse blown
- Battery not connected
- Battery polarity inverted.

Alarm output circuit

BCE2V5 - BCE03

- Type of output:

- Negative static; NPN transistor
- Maximum voltage applicable to load: +V battery terminal
- Maximum output current: 300mA
- Maximum overload current for 1 second: 2A
- Dynamic over-voltage protection with inductive load.

BCE05 - BCE06 - BCE10 - BCE12

- Type of output

- Relay: 1 changeover contact
- Rated voltage: 250VAC
- Maximum admissible voltage: 440VAC
- Rated capacity in AC1 duty: 5A 250VAC lth
- Rated capacity in DC13 or DC14 duty: 5A 30VDC
- Electrical life: >10⁵ cycles
- Mechanical life: >30x10⁵ cycles.

ⓘ The output is not overload or short-circuit protected. It is however capable of switching on a 3W filament bulb.

BCE 0312 - BCE 2V524

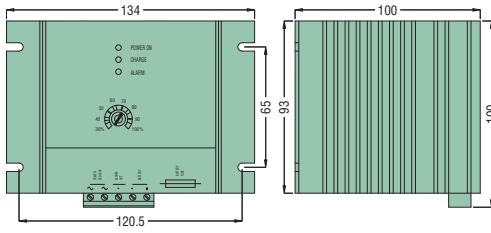

BCE 0612 - BCE 0524

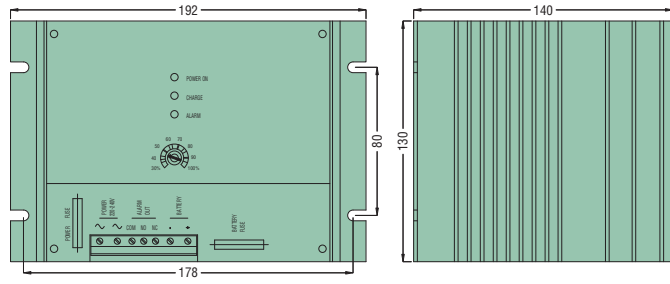

BCE 1212 - BCE 1024

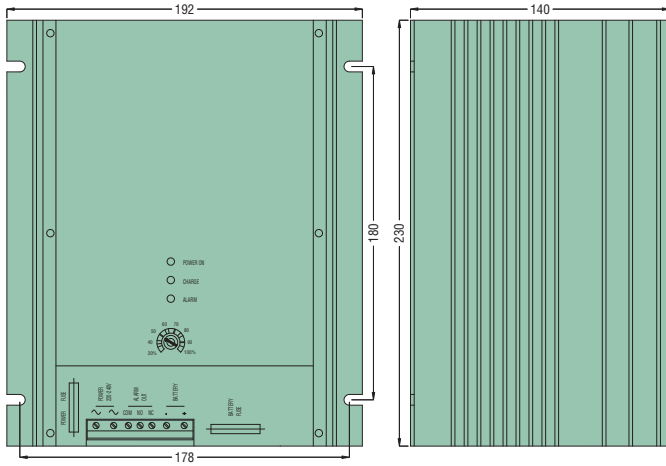

Automatic transfer switch controllers

ATL10

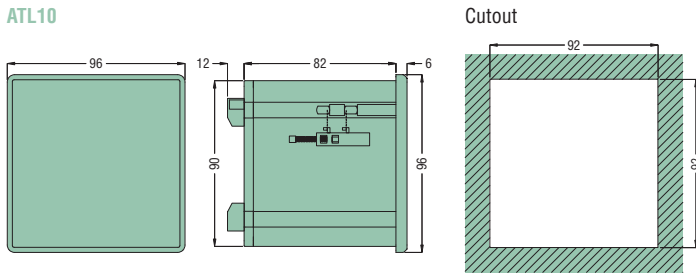

ATL20 - ATL30

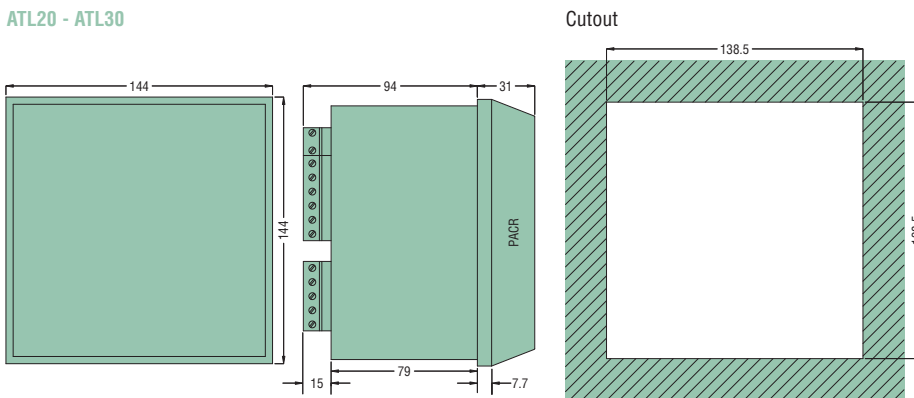

BCE...

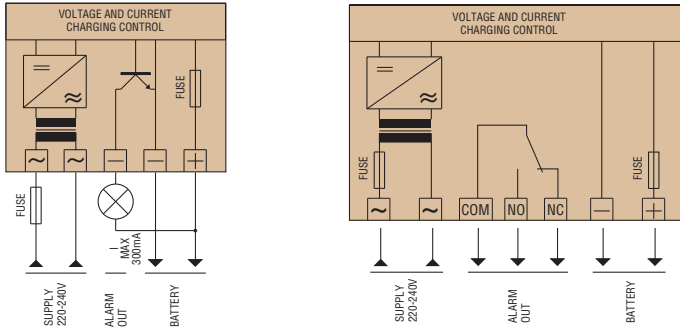

Automatic transfer switch controllers

ATL 10

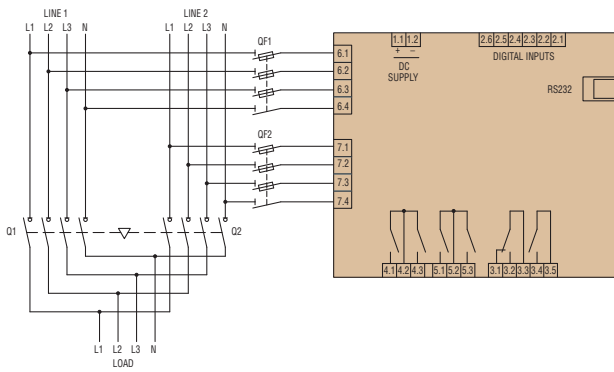

ATL 20 - ATL 30

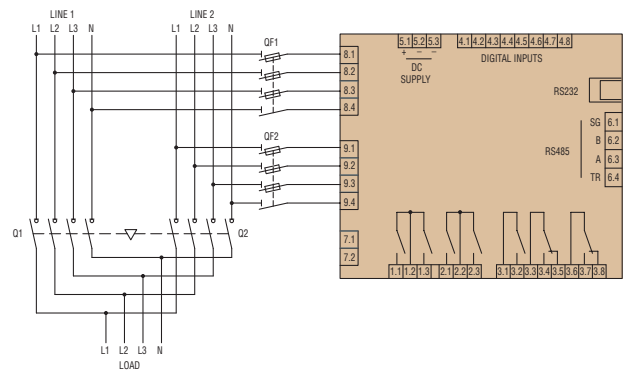

Programmable logic relays

Base relay unit

LRD12R D024

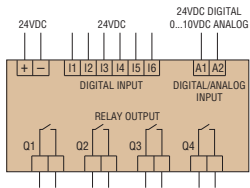

LRD12T D024

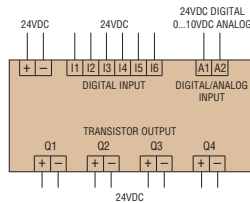

LRD12R A024

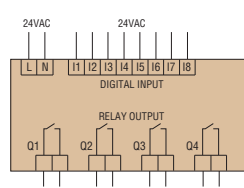

LRD10R A240

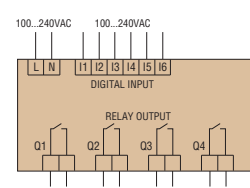

LRD20R D024

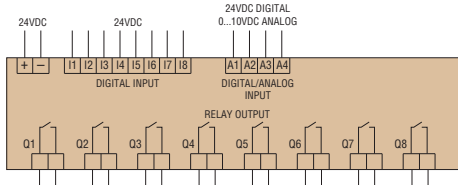

LRD20T D024

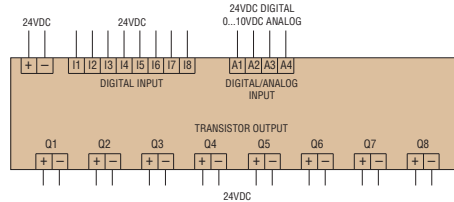

LRD20R A024

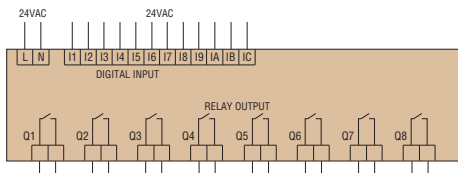

LRD20R A240

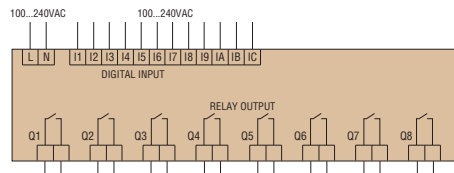

Operational characteristics

TYPE	BCE...
Description	Single phase automatic battery charger 1 charging level for lead-acid batteries
Supply voltage	220-240VAC $\pm 10\%$ 50/60Hz
Rated output voltage U_e	12-24VDC
Rated charging current I_e	3-6-12A (12VDC) 2.5-5-10A (24VDC)
CHARGING CYCLE	
Reference standards	DIN 41773
Diagram	<p>a - constant current charge b - constant voltage charge</p>
End charge voltage U_c	12V battery: 13.8VDC (2.3V/cell) 24V battery: 27.6VDC (2.3V/cell)
Charge current I_c	Adjustable 30% to 100% I_e (using potentiometer on front)
Current limit	Yes
PROTECTIONS	
	<ul style="list-style-type: none"> - Mains supply fuse (5, 6, 10, 12A types only) - Battery output fuse - Charging inhibition due to: <ul style="list-style-type: none"> • short circuit at battery terminals • battery polarity inverted • low voltage at battery poles ($< 0.5 U_e$) • disconnected battery
ALARM OUTPUT CIRCUIT	
	Static output (NPN transistor) ❶; relay with 1 changeover contact, 5A 250VAC ❷
AMBIENT CONDITIONS	
Operating temperature	-10...+50°C
Storage temperature	-30...+80°C
HOUSING	
Version	Open frame
Degree of protection	IP00
Cooling	Natural
Connections	Removable/plug-in terminals ❶ Fixed terminals ❷

❶ For 2.5A and 3A types only.

❷ For 5, 6, 10 and 12A types only.